

HYDRAULIC STEERING FOR INBOARD MOTORS & JETS

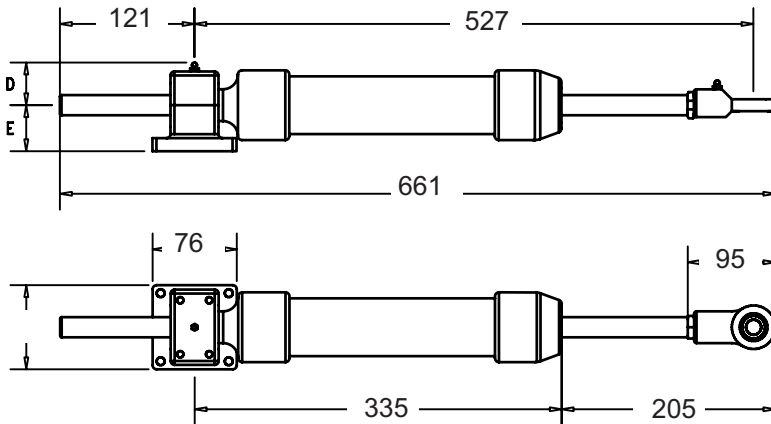

IBKIT-4-C

For Inboard rudders or jets - Model 213 cylinder
Rudder torque:-110KgM



Model 213 Cylinder dimensions

Capacity:- 174cc
Stroke:- 204mm
Weight:- 5Kg

Rod End

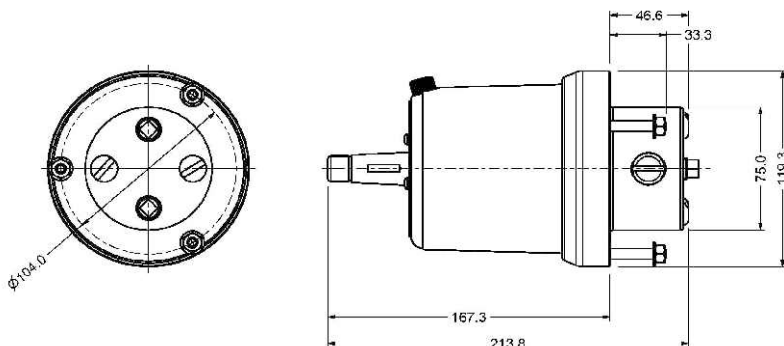

Model 401 and 402 Helm pump dimensions

Model 401 Capacity:-28cc/rev
Model 402 Capacity:-35cc/rev
In-built Lock valve
Maximum working pressure:- 1000psi
Absolute maximum pressure:- 1500psi
Weight:- 5Kg

See also optional helm choices for front-mount and tilting helms for this kit

IBKIT-4

Complete Kit comprises:-
Model 401 Helm
Model 213C12 cylinder
2 litres ULTRA-15 fluid
1 pair high pressure flex hoses
to suit 1/2" copper tubing
Bleeding Kit
All fittings
Installation Manual
Packed weight 15Kg

SIMPLE INSTALLATION TO ANY INBOARD**
See steering circuits for multiple rudders and catamaran installation options.

WHEEL TURNS

lock to lock
401 helm = 6.2
402 helm = 4.9

NOTE: This system should be used with only steel or copper tubing - 1/2"OD

