

HYDRAULIC STEERING FOR INBOARD MOTORS & JETS

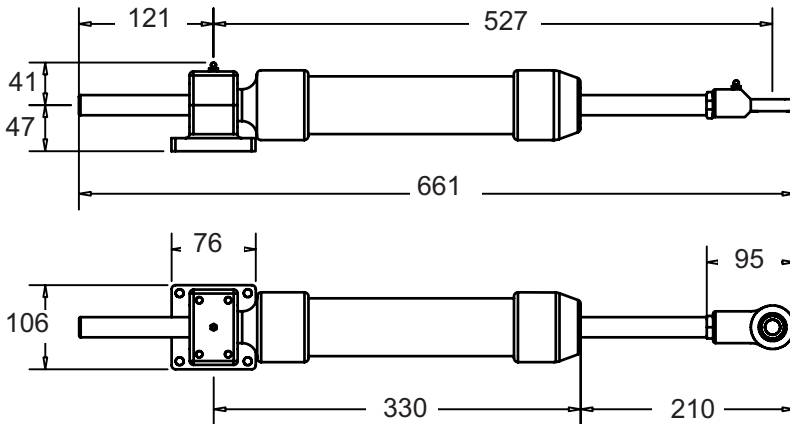

IBKIT-1

For Inboard rudders or jets - Model 210 cylinder
Rudder torque:-85KgM



Model 210 Cylinder dimensions

Capacity:- 154cc
Stroke:- 204mm
Weight:- 5Kg

Rod End

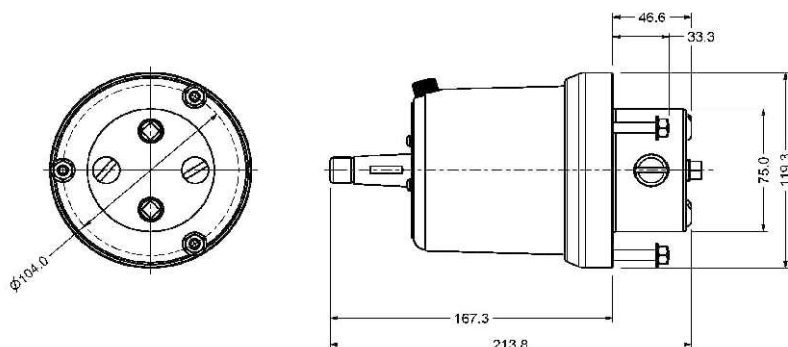

Model 401 and 402 Helm pump dimensions

Model 401 Capacity:-28cc/rev
Model 402 Capacity:-35cc/rev
In-built Lock valve
Maximum working pressure:- 1000psi
Absolute maximum pressure:- 1500psi
Weight:- 5Kg

See also optional helm choices for front-mount and tilting helms for this kit

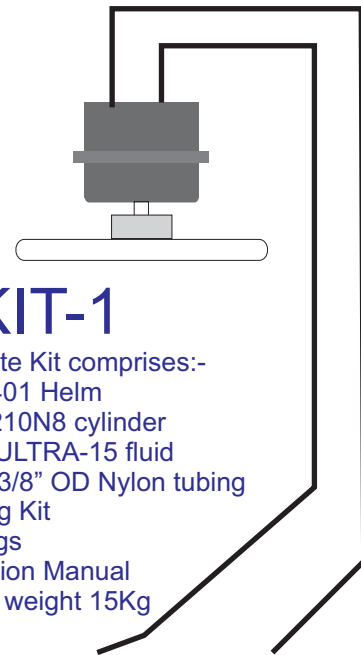

IBKIT-1

Complete Kit comprises:-
Model 401 Helm
Model 210N8 cylinder
2 litres ULTRA-15 fluid
15Mtrs 3/8" OD Nylon tubing
Bleeding Kit
All fittings
Installation Manual
Packed weight 15Kg

SIMPLE INSTALLATION TO ANY INBOARD**
See steering circuits for multiple rudders and catamaran installation options.

WHEEL TURNS

lock to lock
401 helm = 5.5
402 helm = 4.4